

13.3" Capacitive Touch Monitor



- Patented IP65 Front with silicon seal
- Strengthened cover glass
- Anti glare treatment (chemical etching)
- 10-finger-multi touch capacitive touch
- LED backlight backed Panels in A+ quality
- Screwable connection for rugged environments



faytech's Capacitive Touch Monitor series has a modern sleek look with its flat edge to edge glass front panels, and a patented silicone rubberized seal making the front panels IP65 water- and dust proof.

This new series comes with capacitive 10-finger multi-touch, glass front reaching MosH 7, the glass surface is anti glare treated (chemical etched), a wide variety of connectors including USB-B for touch, HDMI, DVI-D, VGA and audio inputs, all lockable including the DC-IN. Each capacitive Touch Monitor has an A+ industrial LCD panel backed by faytech's 100% no dead pixel guarantee. Each monitor comes with its own desktop stand, and screw patterns on the back for VESA 100 mounts.

The high resolution support (e.g. 768p, 1920x1200 pixels) of these faytech touch devices make them the perfect choice for a wide variety of applications including POS systems, as control panels in industrial fields, in kiosk systems, for office/residence automation and many other areas.

The projected 10-point capacitive touch panel is accurate and responsive. The touch function is quickly established when connected via USB port. faytech includes touch drivers for popular OS (Win CE, XP, Vista, 7, 8, 10), Mac, Android and Linux. Normally, no touch driver needed for Win 7, 8 and 10. The virtual keyboard and Windows gesture makes Windows convenient to use. Besides, embedded systems, such as Raspberry Pi, are supported as well.

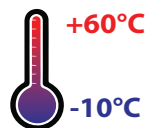

Product name	13.3" Capacitive Touch Monitor
Article code / EAN numer	FT133TMBCAP / 6920734013104

LCD Panel	
IP rating	IP65 Front / IP40 Back
Screen diagonal (Inch/cm)	13.3/33.78
Display active screen size (cm)	29.37×16.52
Aspect ratio	16:9
Physical resolution	1920×1080
Maximum showable resolution	1920×1080
Colours displayed	16.7M
Brightness (cd/m ²)	350
Contrast	700:1
Typical reaction time Tr/ Tf (ms)	14/11
Visual Angle horizontal/vertical (°)	178/178
Backlight / Backlight Lifetime (hours)	LED / min. 15,000

External Connectors	
Video	1x VGA
	1x DVI-D
	1x HDMI 1.3 (incl. HDCP)
Audio	1x PC-Audio
Touch Connector	1x USB
Connectors	1x 12V DC-IN

Touch Panel	
Touch Technology	Projected Capacitive 10-point Multitouch
Touch Connector	USB
Touch Panel Drivers	Windows; Linux; Mac; Android
Touch Life (Contacts)	Unlimited
Surface Hardness	7H
Surface Treatment	Chemical etched Anti Glare effect

Operation / Mechanical	
Operating Temperature (°C)	-10 ~ +60
Humidity Range (RH)	10%-90%
Net weight (kg)	1.5
Gross weight (kg)	3.5 (incl. cartonage)
Housing material	Rubber front case and Plastic back case
Housing (cm) LxWxH	34.70 x 21.90 x 3.60
Mounting	VESA 100

Power	
Power Indicator	Green LED
Power Supply	100-240V ACDC active switching; 12V DC-Out
Working Power (V)	12
Power Consumption (W)	12
Stand-By Consumption (W)	<1

Included in the Delivery	
Power Supply (see Power section)	
Driver DVD	
Short Installation Manual	
Cables - VGA, USB Touch, Audio Cable	
Standard Stand	

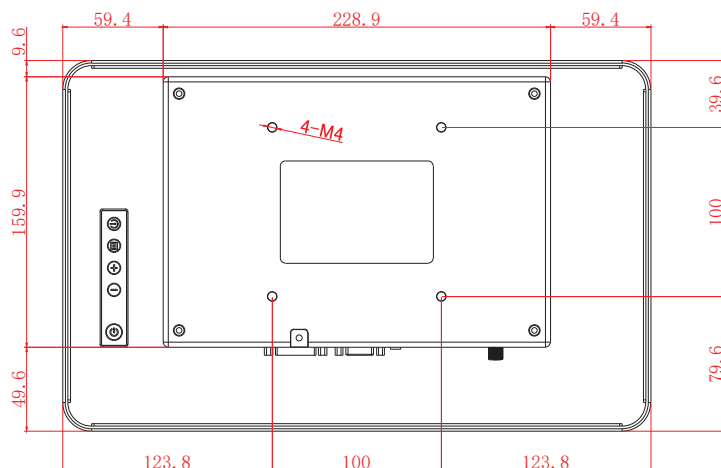
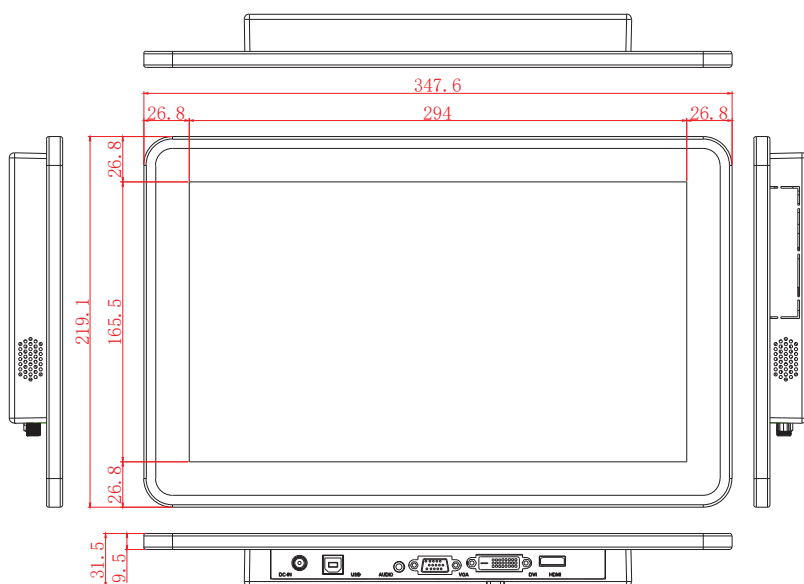

8 rue du Colonel Chambonnet
69500 BRON - FRANCE
04 72 14 18 00
info@ip-systemes.fr
www.ip-systemes.com