

GOT5840T-834

8.4" SVGA TFT Fanless Touch Panel Computer with Intel® Celeron® Processor J1900

Features

- 8.4" SVGA TFT LCD display with LED backlight
- Fanless cooling system with Intel® Celeron® processor J1900
- Ultra slim and super light design
- WLAN module and internal antenna
- PCI Express Mini Card slots for easy expansion
- 2 GbE LAN, 2 USB & 2 COM
- Supports panel mount/wall mount/VESA arm
- Plastic and IP65-rated front bezel



▲ Side view



▲ Desktop stand

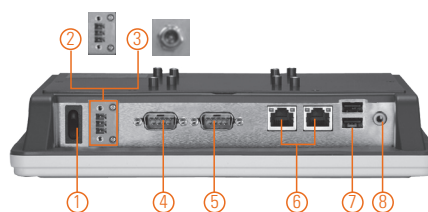

1. Power switch (ATX)
2. Terminal block for DC power input or or
3. Screw conn. w/ AC power adapter
4. COM 1 (RS-232/422/485)
5. COM 2 (RS-232/422/485)
6. Ethernet x 2
7. USB 3.0 x 2
8. Audio (Line-out)



Introduction

The GOT5840T-834 is an 8.4" Intel® Celeron®-based fanless touch panel computer. In response to market demand, this panel computer is a cost effective solution. It adopts a modern, super sleek and fanless design and is equipped with a 8.4" TFT LCD as well as Intel® Celeron® processor J1900 (Bay Trail). For wireless network connection, the GOT5840T-834 offers 2 PCI Express Mini Card slots. By just plugging in the mini card WLAN card, customers can have instant access to wireless LAN/GPRS/GSM/4G environments. Besides, it provides two types of power input. One is DC power input (9 to 36 VDC) with terminal block connector, and another is AC power adapter with screw type connector.

Super Slim & Ultra Lightweight Design

The GOT5840T-834 is a super slim touch panel computer for space-limited environment with its thickness of 45 mm and weight of 1.3 kg only, which make it installed everywhere.

Built-in Internal WLAN Antenna

The GOT5840T-834 provides 2 PCI Express Mini Card slots and a built-in WLAN antenna for wireless network connections. By simply plugging in the wireless LAN card, customers can use the GOT5840T-834 in a wireless LAN/GPRS/GSM/4G environments.

Aluminum Back Chassis Excellent with Thermal Solution

With Axiomtek's patent for plastic plus aluminum mechanism design, the GOT5840T-834 can dissipate the heat easily and keep the system operation stable.

Specifications

Front Bezel	IP65, NEMA 4 rugged protection, plastic front bezel	
LCD Panel	Display Type	8.4" SVGA TFT LCD with LED backlight
	Brightness (cd/m ²)	350 nits
	Resolution	800 x 600
	Viewing Angel (H/V)	160°/140°
Main System	CPU	Intel® Celeron® processor J1900 4 cores
	System Memory	1 x 204-pin DDR3L-1333 MHz SO-DIMM, up to 8GB
	BIOS	AMI UEFI BIOS
	Storage	1 x CFast™ or mSATA
	Watchdog Timer	255 levels, 0 to 255 sec.
	Onboard Graphics	Integrated in Intel® GFX

Specifications

I/O Connector	2 x RS-232/422/485 (default RS-232, COM 1/2) 2 x USB 3.0 2 x 10/100/1000 Mbps Ethernet (Intel® i210IT) 1 x Audio (Line-out)
TPM	N/A
Expansion Interface	1 x full-size PCI Express Mini Card slot with mSATA 1 x full-size PCI Express Mini Card slot with SIM
Touchscreen	Resistive type
Power Input	1. DC version: 9 to 36 VDC with over-current protection fuse 2. AC version: 100 to 240 V AC-DC, 60W power adapter
Power Consumption	25 W
Dimensions	250.7 mm (9.87") (W) x 45.8 mm (1.80") (D) x 204.7 mm (8.06") (H)
Packing Dimensions	380 mm (14.96") (W) x 100 mm (3.94") (D) x 280 mm (11.02") (H)
Weight (net/gross)	1.3 kg (2.87 lb) / 2.25 kg (4.96 lb)
Environment	Operating temperature: 0°C to +50°C (+32°F to +122°F) (with W.T. DRAM/HDD in airflow condition) 0°C to +45°C (+32°F to +113°F) (with W.T. DRAM) Relative humidity: 20% to 90% @ +40°C; non-condensing Operation vibration: 2G, 5 to 500 Hz, random for CFast™
Certificate	CE

Packing List

- 1 x GOT5840T-834
- 1 x Driver CD
- 1 x Adapter (GOT5840T-834-J)
- 1 x Panel mount kit
- 1 x Wall mount kit
- 1 x Phoenix connector (GOT5840T-834 DC)

Ordering Information

GOT5840T-834-J	8.4" SVGA fanless touch panel computer with Intel® Celeron® processor J1900, 5-wire resistive touch screen, AC-DC 60W power adapter (screw type connector) and EMI class B
GOT5840T-834-DC	8.4" SVGA fanless touch panel computer with Intel® Celeron® processor J1900, 5-wire resistive touch screen and 9 to 36 VDC power input (terminal block connector)

Optional

Wi-Fi + Bluetooth kit	
E226171106	Stand kit
881251203A0E	RFID kit

* Specification and certifications are based on requirements and may vary.

Optional EOS Installation

WES 7
WE8S
Windows® 10 IoT Enterprise

Optional OS Installation

Windows® 7
Windows® 8.1
Windows® 10



▲ AC power adapter (for GOT5840T-834-J)

Dimensions

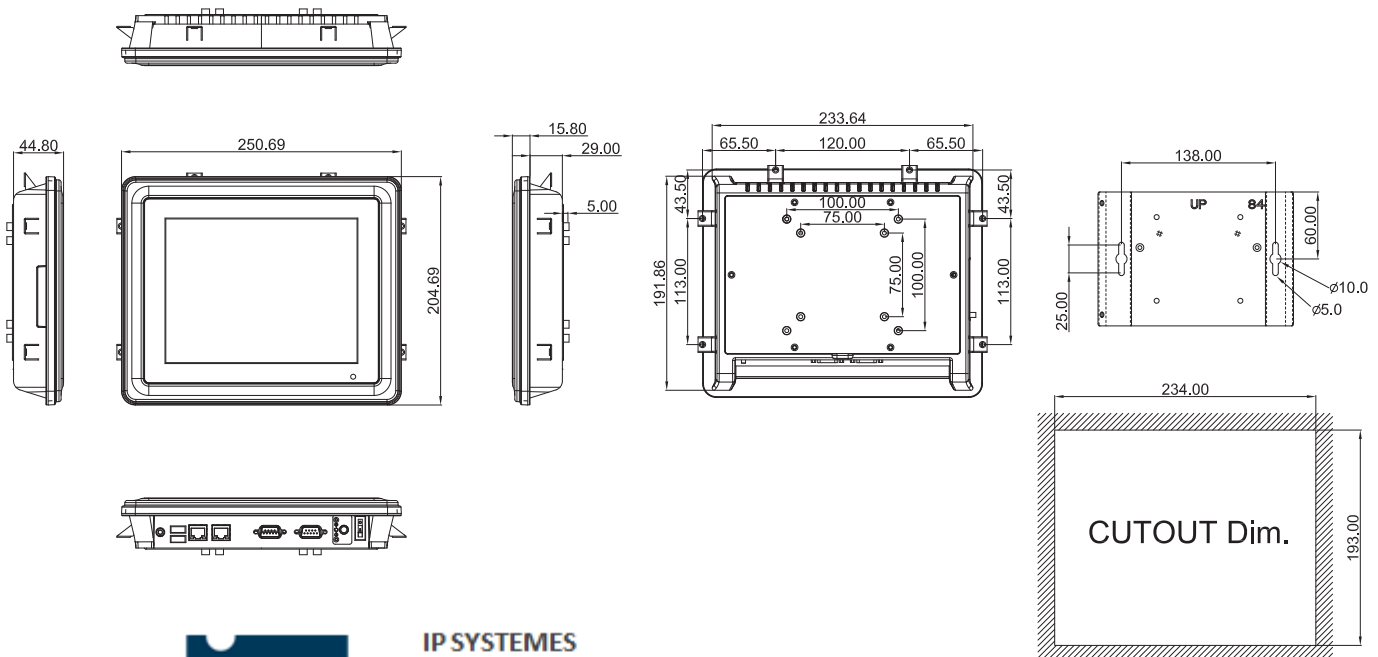

IP SYSTEMES
 8 rue du Colonel Chambonnet – BP67
 69672 BRON Cedex
 Tel. : 04 72 14 18 00
 Fax : 04 72 14 18 01
www.ip-systemes.com – info@ip-systemes.fr